

**PT COUPLING CO. INC.
GENERAL DIMENSIONS**

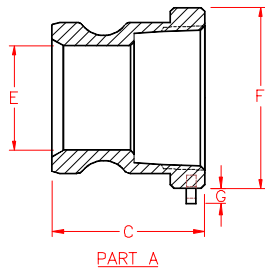

PART A

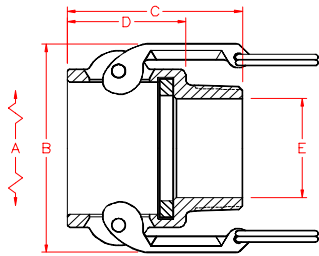

PART B

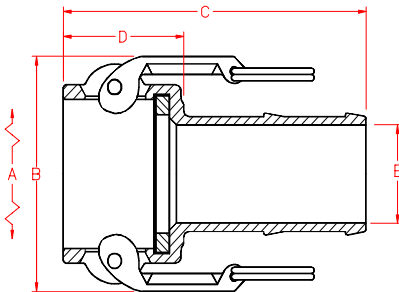

PART C

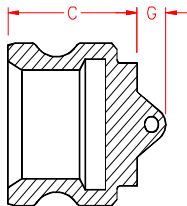

PART W

REF	DESCRIPTION	PART A (ADAPTER X FEMALE THREAD)															
		E05	05	07	10	12	15	20	25	30	40	50	60	80	100	120	
	COUPLER OR ADAPTER SIZE	.50	.75	.75	1.00	1.25	1.50	2.00	2.50	3.00	4.00	5.00	6.00	8.00	10.00	12.00	
	THREAD SIZE	.50	.50	.75	1.00	1.25	1.50	2.00	2.50	3.00	4.00	5.00	6.00	8.00	10.00	12.00	
C	OVERALL LENGTH in/(mm)	1.60 (41)	1.62 (41)	1.62 (41)	1.91 (49)	2.16 (55)	2.29 (58)	2.54 (65)	2.75 (70)	2.84 (72)	3.16 (80)	3.22 (82)	3.35 (85)	4.50 (114)	4.50 (114)	4.38 (111)	
E	INSIDE DIAMETER in/(mm)	.53 (13)	.66 (17)	.75 (20)	.88 (22)	1.04 (26)	1.35 (34)	1.72 (44)	2.14 (54)	2.80 (71)	3.78 (96)	4.79 (122)	5.90 (150)	7.80 (198)	10.10 (257)	12.00 (305)	
F	ACROSS CORNERS in/(mm)	1.12 (28)	1.49 (38)	1.49 (38)	1.76 (45)	2.19 (56)	2.44 (62)	2.92 (74)	3.49 (89)	4.22 (107)	5.41 (137)	6.49 (165)	7.70 (196)	10.23 (260)	12.79 (325)	14.75 (375)	
G	CHAIN LUG EXTENSION in/(mm)					.34 (9)	.33 (8)	.31 (8)	.27 (7)	.44 (11)	.39 (10)	.35 (9)					
REF	DESCRIPTION	PART B (COUPLER X MALE THREAD)															
		E05	05	07	10	12	15	20	25	30	40	50	60	80	100	120	
	COUPLER OR ADAPTER SIZE	.50	.75	.75	1.00	1.25	1.50	2.00	2.50	3.00	4.00	5.00	6.00	8.00	10.00	12.00	
	THREAD SIZE	.50	.50	.75	1.00	1.25	1.50	2.00	2.50	3.00	4.00	5.00	6.00	8.00	10.00	12.00	
A	O.D. WITH CAM ARMS EXTENDED in/(mm)	4.21 (107)	4.51 (115)	4.51 (115)	5.10 (130)	6.86 (174)	7.16 (182)	7.54 (192)	8.03 (204)	9.56 (243)	10.66 (271)	11.67 (296)	16.26 (413)	18.23 (463)	20.66 (525)	22.72 (577)	
B	OUTSIDE DIAMETER in/(mm)	1.82 (46)	2.11 (54)	2.11 (54)	2.44 (62)	3.26 (83)	3.56 (90)	3.94 (100)	4.43 (113)	5.46 (139)	6.56 (167)	7.57 (192)	10.16 (258)	12.13 (308)	14.56 (370)	16.62 (422)	
C	OVERALL LENGTH in/(mm)	2.10 (53)	2.10 (53)	2.10 (53)	2.50 (64)	2.89 (73)	2.93 (74)	3.20 (81)	3.63 (92)	3.82 (97)	4.00 (102)	4.20 (107)	4.52 (115)	4.80 (122)	5.50 (140)	5.70 (145)	
D	EXPOSED LENGTH in/(mm)	1.25 (32)	1.25 (32)	1.25 (32)	1.56 (40)	1.84 (47)	1.88 (48)	2.15 (55)	2.18 (55)	2.27 (58)	2.34 (59)	2.44 (62)	2.62 (67)	2.72 (69)	3.20 (81)	3.20 (81)	
E	INSIDE DIAMETER in/(mm)	.56 (14)	.56 (14)	.78 (20)	.97 (25)	1.25 (32)	1.50 (38)	1.88 (48)	2.38 (60)	2.88 (73)	3.60 (91)	4.50 (114)	5.60 (142)	7.50 (191)	9.40 (239)	11.40 (290)	
REF	DESCRIPTION	PART C (COUPLER X HOSE SHANK)															
		E05	05	07	10	12	15	20	25	30	40	50	60	80	100	120	
	COUPLER OR ADAPTER SIZE	.50	.75	.75	1.00	1.25	1.50	2.00	2.50	3.00	4.00	5.00	6.00	8.00	10.00	12.00	
	HOSE SHANK SIZE	.50	.50	.75	1.00	1.25	1.50	2.00	2.50	3.00	4.00	5.00	6.00	8.00	10.00	12.00	
A	O.D. WITH CAM ARMS EXTENDED in/(mm)	4.21 (107)	4.51 (115)	4.51 (115)	5.10 (130)	6.86 (174)	7.16 (182)	7.54 (192)	8.03 (204)	9.56 (243)	10.66 (271)	11.67 (296)	16.26 (413)	18.23 (463)	20.66 (525)	22.72 (577)	
B	OUTSIDE DIAMETER in/(mm)	1.82 (46)	2.11 (54)	2.11 (54)	2.44 (62)	3.26 (83)	3.56 (90)	3.94 (100)	4.43 (113)	5.46 (139)	6.56 (167)	7.57 (192)	10.16 (258)	12.13 (308)	14.56 (370)	16.62 (422)	
C		2.69 (68)	2.7 (69)	3.55 (90)	4.06 (103)	4.44 (113)	4.82 (122)	5.53 (140)	5.93 (151)	6.32 (161)	6.64 (169)	7.24 (184)	9.5 (241)	9.5 (241)	12 (305)	12 (305)	
D	EXPOSED LENGTH in/(mm)	1.25 (32)	1.25 (32)	1.25 (32)	1.56 (40)	1.84 (47)	1.88 (48)	2.15 (55)	2.18 (55)	2.27 (58)	2.34 (59)	2.44 (62)	2.7 (69)	2.72 (69)	3.2 (81)	3.3 (81)	
E	INSIDE DIAMETER in/(mm)	0.38 (10)	0.38 (10)	0.53 (13)	0.78 (20)	0.97 (25)	1.22 (31)	1.71 (43)	2.16 (55)	2.65 (67)	3.53 (90)	4.53 (115)	5.53 (140)	7.53 (191)	9.4 (239)	11.4 (290)	
E*	MIN. INSIDE DIAMETER in/(mm)	.33 (8)	.33 (8)	.40 (10)	.69 (18)	.88 (22)	1.15 (29)	1.60 (41)	2.06 (52)	2.55 (65)	3.43 (87)	4.43 (113)	5.43 (138)	7.38 (187)	9.2 (234)	11.3 (287)	
REF	DESCRIPTION	PART W (ADAPTER DUST PLUG)															
		E05	05	07	10	12	15	20	25	30	40	50	60	80	100	120	
	COUPLER OR ADAPTER SIZE	.50		.75	1.00	1.25	1.50	2.00	2.50	3.00	4.00	5.00	6.00	8.00	10.00		
C	OVERALL LENGTH in/(mm)	1.06 (27)		1.41 (36)	1.35 (34)	1.94 (49)	2.06 (52)	1.90 (48)	2.44 (62)	2.03 (52)	2.10 (53)	2.63 (67)	2.28 (58)	2.28 (58)	3 (76)		
G	CHAIN LUG EXTENSION in/(mm)	.50 (13)		.59 (15)	.96 (24)	.62 (16)	.50 (13)	.70 (18)	.81 (21)	1.00 (25)	1.00 (25)	.85 (22)	1.00 (25)	1.18 (30)	0.9 (23)		

**PT COUPLING CO. INC.
GENERAL DIMENSIONS**

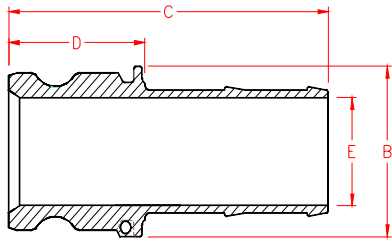

PART E

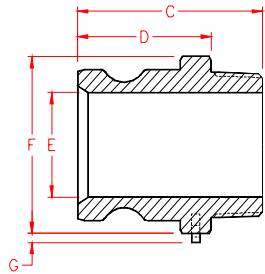

PART F

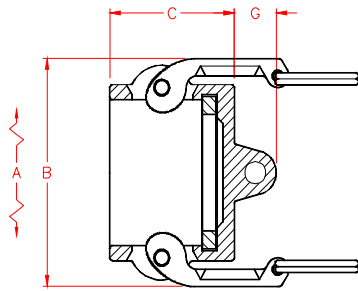

PART V

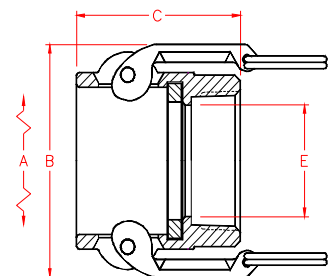

PART D

PART E (ADAPTER X HOSE SHANK)																
REF	DESCRIPTION	E05	05	07	10	12	15	20	25	30	40	50	60	80	100	120
	COUPLER OR ADAPTER SIZE	.50	.75	.75	1.00	1.25	1.50	2.00	2.50	3.00	4.00	5.00	6.00	8.00	10.00	12.00
	HOSE SHANK SIZE	.50	.50	.75	1.00	1.25	1.50	2.00	2.50	3.00	4.00	5.00	6.00	8.00	10.00	12.00
B	OUTSIDE DIAMETER in/(mm)	0.96 (24)	1.26 (32)	1.26 (32)	1.63 (41)	2 (51)	2.14 (54)	2.64 (67)	3.07 (78)	3.70 (94)	4.71 (120)	6.56 (167)	7.1 (180)	9.1 (231)	11.37 (289)	13.46 (342)
C	OVERALL LENGTH in/(mm)	2.56 (65)	3.21 (82)	3.78 (96)	4.3 (109)	4.90 (124)	5.10 (130)	5.75 (146)	6.63 (168)	6.88 (175)	7.2 (183)	7.56 (192)	10.1 (257)	10.1 (257)	11.7 (297)	11.7 (297)
D	EXPOSED LENGTH in/(mm)	1.11 (28)	1.46 (37)	1.46 (37)	1.8 (46)	2.35 (60)	2.15 (55)	2.40 (61)	2.47 (63)	2.53 (64)	2.60 (66)	2.81 (71)	3.3 (84)	3.3 (84)	2.88 (73)	2.88 (73)
E	INSIDE DIAMETER in/(mm)	0.38 (10)	0.35 (9)	0.53 (13)	0.88 (22)	0.97 (25)	1.19 (30)	1.68 (43)	2.13 (54)	2.62 (67)	3.50 (89)	4.53 (115)	5.53 (140)	7.53 (191)	9.4 (239)	11.4 (290)

PART F (ADAPTER X MALE THREAD)																
REF	DESCRIPTION	E05	05	07	10	12	15	20	25	30	40	50	60	80	100	120
	COUPLER OR ADAPTER SIZE	.50	.75	.75	1.00	1.25	1.50	2.00	2.50	3.00	4.00	5.00	6.00	8.00	10.00	
	THREAD SIZE	.50	.50	.75	1.00	1.25	1.50	2.00	2.50	3.00	4.00	5.00	6.00	8.00	10.00	
C	OVERALL LENGTH in/(mm)	1.96 (50)	2.47 (63)	2.47 (63)	2.89 (73)	3.23 (82)	3.29 (84)	3.57 (91)	4.18 (106)	4.37 (111)	4.79 (122)	4.91 (125)	5.20 (132)	5.90 (150)	6.75 (171)	
D	EXPOSED LENGTH in/(mm)	1.26 (32)	1.67 (42)	1.67 (42)	1.99 (51)	2.23 (57)	2.31 (59)	2.57 (65)	2.78 (71)	2.87 (73)	3.19 (81)	3.21 (82)	3.40 (86)	3.90 (99)	4.38 (111)	
E	INSIDE DIAMETER in/(mm)	0.53 (13)	0.56 (14)	0.75 (19)	0.85 (22)	1.04 (26)	1.34 (34)	1.72 (44)	2.14 (54)	2.80 (71)	3.78 (96)	4.79 (122)	5.84 (148)	7.80 (198)	9.88 (251)	
F	MAX. ACROSS CORNERS in/(mm)	1.12 (28)	1.42 (36)	1.42 (36)	1.75 (45)	2.16 (55)	2.44 (62)	2.84 (72)	3.45 (88)	4.07 (103)	5.27 (134)	6.39 (162)	7.70 (196)	10.00 (254)	11.87 (301)	
G	CHAIN LUG EXTENSION in/(mm)					0.34 (9)	0.30 (8)	0.28 (7)	0.29 (7)	0.44 (11)	0.40 (10)	0.16 (4)				

PART V (COUPLER DUST CAP)																
REF	DESCRIPTION	E05	05	07	10	12	15	20	25	30	40	50	60	80	100	120
	COUPLER OR ADAPTER SIZE	.50		.75	1.00	1.25	1.50	2.00	2.50	3.00	4.00	5.00	6.00	8.00	10.00	12.00
A	O.D. WITH CAM ARMS EXTENDED in/(mm)	4.21 (107)		4.51 (115)	5.10 (130)	6.86 (174)	7.16 (182)	7.54 (192)	8.03 (204)	9.56 (243)	10.66 (271)	11.67 (296)	16.26 (413)	18.23 (463)	20.66 (525)	22.72 (577)
B	OUTSIDE DIAMETER in/(mm)	1.82 (46)		2.11 (54)	2.44 (62)	3.26 (83)	3.56 (90)	3.94 (100)	4.43 (113)	5.46 (139)	6.56 (167)	7.57 (192)	10.16 (258)	12.13 (308)	14.56 (370)	16.62 (422)
C	OVERALL LENGTH in/(mm)	1.3 (33)		1.35 (34)	1.60 (41)	1.89 (48)	1.96 (50)	2.25 (57)	2.28 (58)	2.27 (58)	2.34 (59)	2.44 (62)	2.76 (70)	2.72 (69)	3.30 (84)	3.50 (89)
G	CHAIN LUG EXTENSION in/(mm)	0.5 (13)		0.5 (13)	0.62 (16)	0.6 (15)	0.86 (22)	0.76 (19)	0.90 (23)	1.03 (26)	0.99 (25)	1.15 (29)	1.14 (29)	1.18 (30)	1.30 (33)	1.30 (33)

PART D (COUPLER X FEMALE THREAD)																
REF	DESCRIPTION	E05	05	07	10	12	15	20	25	30	40	50	60	80	100	120
	COUPLER OR ADAPTER SIZE	.50	.75	.75	1.00	1.25	1.50	2.00	2.50	3.00	4.00	5.00	6.00	8.00	10.00	12.00
	THREAD SIZE	.50	.50	.75	1.00	1.25	1.50	2.00	2.50	3.00	4.00	5.00	6.00	8.00	10.00	12.00
A	O.D. WITH CAM ARMS EXTENDED	4.21 (107)	4.51 (115)	4.51 (115)	5.10 (130)	6.86 (174)	7.16 (182)	7.54 (192)	8.03 (204)	9.56 (243)	10.66 (271)	11.67 (296)	16.26 (413)	18.23 (463)	20.66 (525)	22.72 (577)
B	OUTSIDE DIAMETER in/(mm)	1.82 (46)	2.11 (54)	2.11 (54)	2.44 (62)	3.26 (83)	3.56 (90)	3.94 (100)	4.43 (113)	5.46 (139)	6.56 (167)	7.57 (192)	10.16 (258)	12.13 (308)	14.56 (370)	16.62 (422)
C	OVERALL LENGTH in/(mm)	2 (51)	2.1 (53)	2.1 (53)	2.5 (64)	2.7 (69)	2.8 (71)	3.1 (79)	3.4 (86)	3.5 (89)	3.9 (99)	4.1 (104)	4.4 (112)	4.8 (122)	5.5 (140)	5.7 (145)
E	INSIDE DIAMETER in/(mm)	0.67 (17)	0.67 (17)	0.88 (22)	0.97 (25)	1.25 (32)	1.5 (38)	1.88 (48)	2.38 (60)	2.88 (73)	3.6 (91)	4.5 (114)	5.5 (140)	7.5 (191)	9.4 (239)	11.4 (290)

**PT COUPLING CO. INC.
GENERAL DIMENSIONS**

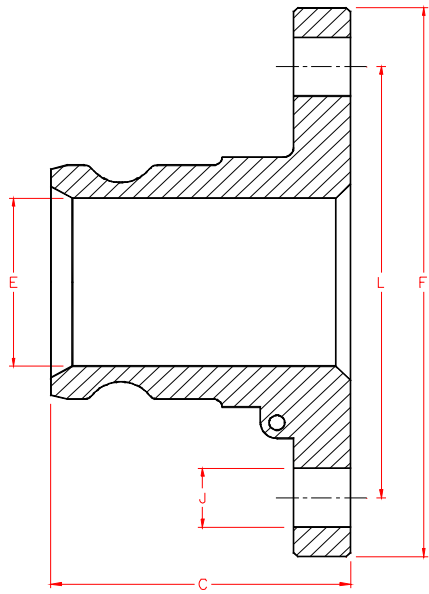

PART PF-A

REF	DESCRIPTION	PART PF-A (ADAPTER X FLANGE)										
		PF10A	PF15A	PF20A	PF25A	PF30A	PF40A	PF50A	PF60A	PF80A	PF100A	PF120A
	ADAPTER SIZE	1.00	1.50	2.00	2.50	3.00	4.00	5.00	6.00	8.00	10.00	12.00
	FLANGE SIZE (ANSI CLASS 150)	1.00	1.50	2.00	2.50	3.00	4.00	5.00	6.00	8.00	10.00	12.00
C	OVERALL LENGTH in/(mm)	2.32 (59)	3.56 (90)	3.5 (89)	3.63 (92)	3.69 (94)	4.0 (102)	4.44 (113)	4.5 (114)	5.38 (137)	6.6 (168)	7.0 (178)
E	INSIDE DIAMETER in/(mm)	.88 (22)	1.34 (34)	1.72 (44)	2.14 (54)	2.78 (71)	3.78 (96)	4.79 (122)	5.56 (141)	7.8 (198)	10.0 (254)	11.4 (290)
F	OUTSIDE DIAMETER in/(mm)	4.25 (108)	5.0 (127)	6.0 (152)	7.0 (178)	7.5 (191)	9.0 (229)	10.0 (254)	11.0 (279)	13.5 (343)	16.0 (406)	19.0 (483)
J	BOLT HOLE DIAMETER in/(mm)	.63 (16)	.63 (16)	.75 (19)	.75 (19)	.75 (19)	.75 (19)	.88 (22)	.88 (22)	.88 (22)	1.0 (25)	1.0 (25)
K	NUMBER OF HOLES	4	4	4	4	4	8	8	8	8	12	12
L	BOLT CIRCLE DIAMETER in/(mm)	3.13 (80)	3.88 (99)	4.75 (121)	5.5 (140)	6.0 (152)	7.5 (191)	8.5 (216)	9.5 (241)	11.75 (298)	14.25 (362)	17.0 (432)

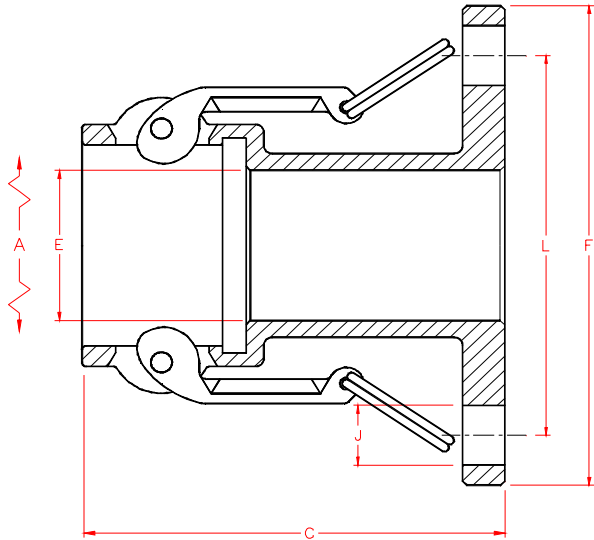

PART PF-C

REF	DESCRIPTION	PART PF-C (COUPLER X FLANGE)							
		PF10C	PF15C	PF20C	PF25C	PF30C	PF40C	PF60C	PF80C
	COUPLER SIZE	1.00	1.50	2.00	2.50	3.00	4.00	6.00	8.00
	FLANGE SIZE (ANSI CLASS 150)	1.00	1.50	2.00	2.50	3.00	4.00	6.00	8.00
A	O.D. WITH CAM ARMS EXTENDED	5.04 (128)	7.16 (182)	7.54 (192)	8.03 (204)	9.56 (243)	10.66 (271)	16.76 (426)	18.73 (476)
C	OVERALL LENGTH in/(mm)	3.48 (88)	5.25 (133)	5.82 (148)	5.09 (129)	5.82 (148)	5.39 (137)	7.75 (197)	7.64 (194)
E	INSIDE DIAMETER in/(mm)	.69 (18)	1.35 (34)	1.63 (41)	2.38 (60)	2.9 (74)	3.6 (91)	5.6 (142)	7.53 (191)
F	OUTSIDE DIAMETER in/(mm)	4.25 (108)	5.0 (127)	6.0 (152)	7.0 (178)	7.5 (191)	9.0 (229)	11.0 (279)	13.5 (343)
J	BOLT HOLE DIAMETER in/(mm)	.63 (16)	.63 (16)	.75 (19)	.75 (19)	.75 (19)	.75 (19)	.88 (22)	.88 (22)
K	NUMBER OF HOLES	4	4	4	4	4	8	8	8
L	BOLT CIRCLE DIAMETER in/(mm)	3.13 (80)	3.88 (99)	4.75 (121)	5.5 (140)	6.0 (152)	7.5 (191)	9.5 (241)	11.75 (298)

**PT COUPLING CO. INC.
GENERAL DIMENSIONS**

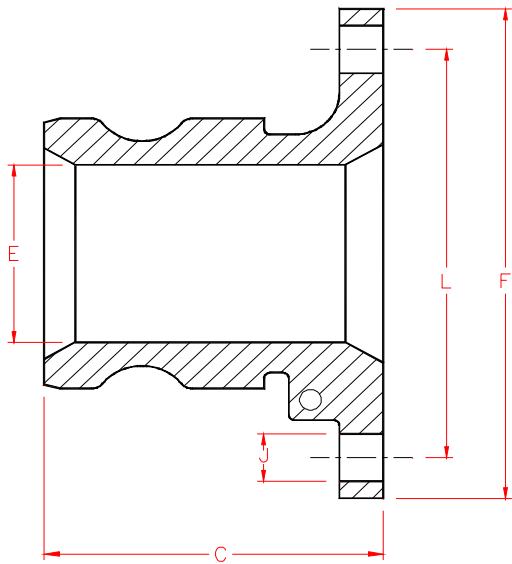

PART TTF-A

		PART TTF-A (ADAPTER X FLANGE)			
REF	DESCRIPTION	TTF20A	TTF30A	TTF40A	TTF60A
	ADAPTER SIZE	2.00	3.00	4.00	6.00
	FLANGE SIZE (TTMA)	2.00	3.00	4.00	6.00
C	OVERALL LENGTH in/(mm)	2.93 (74)	3.38 (86)	3.35 (85)	4.88 (124)
E	INSIDE DIAMETER in/(mm)	1.63 (41)	2.8 (71)	3.78 (96)	5.84 (148)
F	OUTSIDE DIAMETER in/(mm)	4.5 (114)	5.63 (143)	6.63 (168)	8.88 (226)
J	BOLT HOLE DIAMETER in/(mm)	.44 (11)	.44 (11)	.44 (11)	.44 (11)
K	NUMBER OF HOLES	6	8	8	12
L	BOLT CIRCLE DIAMETER in/(mm)	3.75 (95)	4.88 (124)	5.88 (149)	8.13 (207)

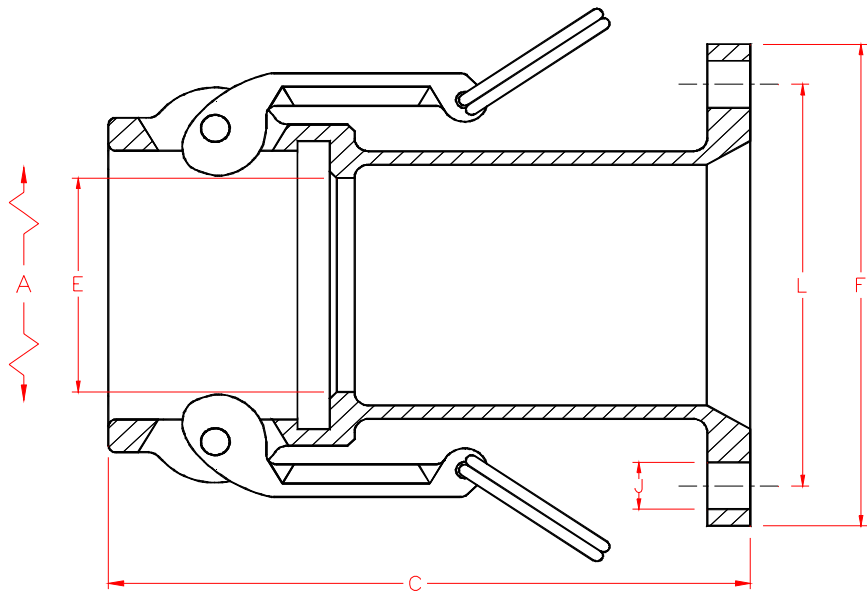

PART TTF-C

		PART TTF-C (COUPLER X FLANGE)				
REF	DESCRIPTION	TTF20C	TTF30C	TTF40C	TTF60C	TTF80C
	COUPLER SIZE	2.00	3.00	4.00	6.00	8.00
	FLANGE SIZE (TTMA)	2.00	3.00	4.00	6.00	8.00
A	O.D. WITH CAM ARMS EXTENDED	7.54 (192)	9.56 (243)	10.66 (271)	16.26 (413)	18.23 (463)
C	OVERALL LENGTH in/(mm)	5.63 (143)	5.66 (144)	5.68 (144)	7.25 (184)	7.64 (194)
E	INSIDE DIAMETER in/(mm)	2.0 (51)	2.9 (74)	3.6 (91)	5.6 (142)	7.53 (191)
F	OUTSIDE DIAMETER in/(mm)	4.5 (114)	5.63 (143)	6.63 (168)	8.88 (226)	10.87 (276)
J	BOLT HOLE DIAMETER in/(mm)	.44 (11)	.44 (11)	.44 (11)	.44 (11)	.44 (11)
K	NUMBER OF HOLES	6	8	8	12	16
L	BOLT CIRCLE DIAMETER in/(mm)	3.75 (95)	4.88 (124)	5.88 (149)	8.13 (207)	10.12 (257)